

Nevco Scoreboard Company

Installation Manual

Serial No. _____

Model 4 Face 2550-D

(Shown with optional AD sign, size and weight not included)

- Size: 12'1" square at top, 9'6" square at bottom, 6' high (3.68x2.90x1.83 meters)
 - Approximate hanging weight: 860 lbs. (390 kg.)
 - Power requirements 120V, 20 Amps
 - UL Listed/c-UL Listed

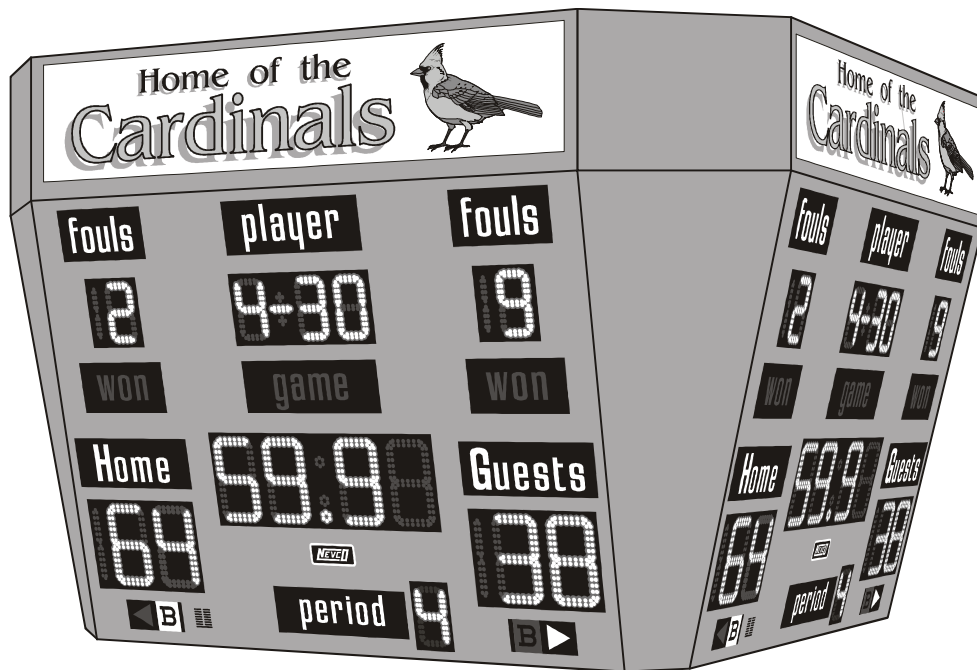

Scoreboards · Message Centers
Video Displays

Since 1934

Retain this manual in your permanent file.

Thank You

Thank you for purchasing from Nevco Scoreboard Company. Below are some important tips to remember when installing your new equipment.

- Pre-test the equipment before installation.
- Consult National Electrical Code and local codes before installation.

Installation Instructions

Unpacking the Equipment

To protect your new scoreboard system from accidental damage, follow the steps below:

- Carefully remove all equipment from its packing carton. **Do not** pry against the scoreboard in any way. Inspect for damage.

Note: If damage to any equipment contact carrier immediately.

- There are electronic modules located inside each face. Consult the included drawings for their exact locations and access methods.
- Make sure all plugs are firmly seated in their proper sockets. If some cables are loose or disconnected, refer to **Module Illustrations**. These prints identify the function of each module plug and show where to connect the cables.

Pre-Test Your Equipment

(4-Face Scoreboard Pre-Mounting Test)

- Connect a length of 2-WIRE cable from the BNC connector on the back of one of the scoreboard faces to the signal source. (control or receiver)
- Connect the scoreboard face to a temporary power service. (See installation print for power service requirements.)
- Follow the Control Hookup & Testing Guide to make sure the system operates properly.
- Check each face before proceeding with the installation of the scoreboard.

Scoreboard Assembly and Mounting

The installation drawings show the typical assembly of, hanging method, and location of power. The drawings also show the assembly of the scoreboard corners. Be sure to overlap sections as illustrated in the detail. Optional AD / ADL signs are shown. Always use good mechanical practices, using all braces and fasteners as shown.

The drawings illustrate the eyebolts in each corner of the cabinet for securing wire rope cable, as required, to support the scoreboard from ceiling anchors. This is a typical method only, for installing 4-face scoreboards. It is the owners responsibility to insure proper method of installation per ceiling and roof stress of each type of building construction.

Power Service Connections

Nevco suggests installation of a dedicated service or circuit for the scoreboard. This eliminates the possibility of overloading the circuit breaker, and guards against service problems in the future. The power requirements will provide a 20% safety factor to guard against nuisance tripping of the circuit breaker.

The contractor or installation personnel will determine the wire length and size required to maintain the voltage necessary to support the circuit load. Nevco recommends the power service maintain 120V at each scoreboard face under maximum load.

Located on the back of each cabinet is a junction box for power connection. Consult the National Electrical Code and local codes before installation.

WIRED INSTALLATION

Make connection from the BNC connector on back of each display to the control point.(junction boxes provided)

WIRELESS INSTALLATION

Run coaxial cable provided from the BNC connector on back of each display to its receiver location.

Installing Cable Connectors

The 2-WIRE cable that comes with your scoreboard does not have connectors attached.

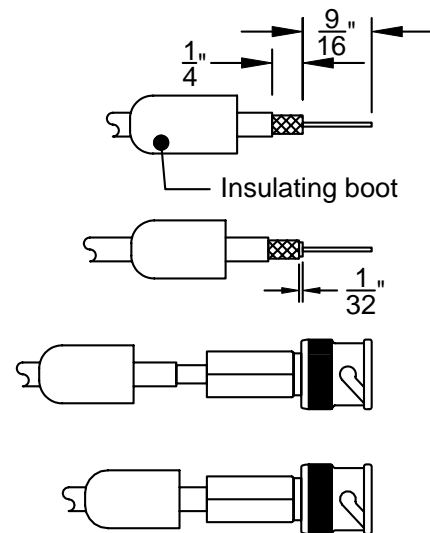

To install connectors on each end of the cable:

- ❑ Slide the insulating boot onto the cable and trim the cable as shown.
- ❑ Twist the outer braid in a **clockwise** direction so that at least 1/32 in. of the inner dielectric is bared and the braid is left flat. Be sure no strands of the outer braid are touching the center conductor.
- ❑ Insert the center conductor into the back of the connector, feeding it into the guide hole.
- ❑ Push the cable as far as possible into the connector.
- ❑ Screw the connector onto the cable in a clockwise direction until the connector stops turning.
- ❑ Slip the insulating boot over the back of the connector.

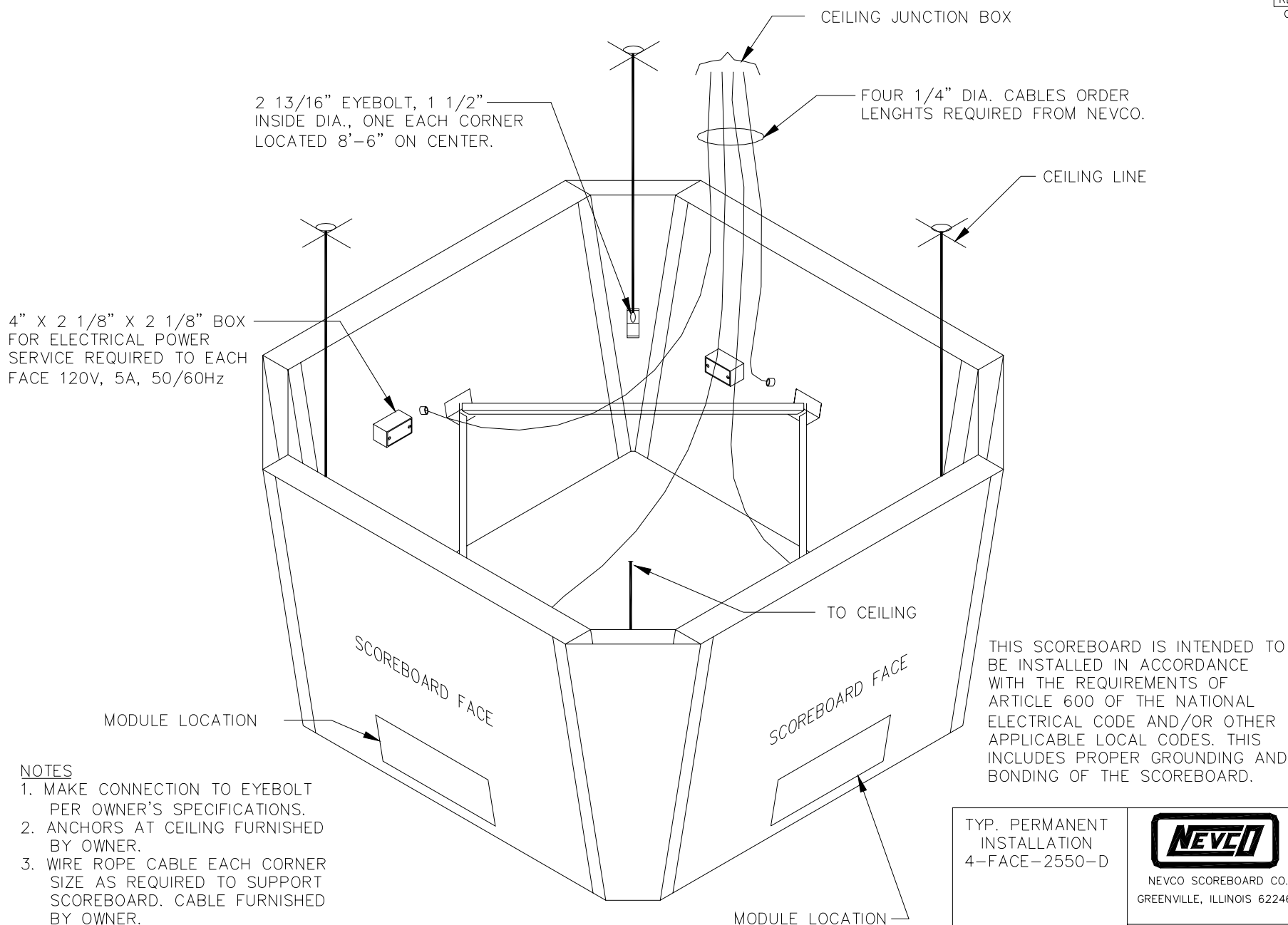

THIS SCOREBOARD IS INTENDED TO BE INSTALLED IN ACCORDANCE WITH THE REQUIREMENTS OF ARTICLE 600 OF THE NATIONAL ELECTRICAL CODE AND/OR OTHER APPLICABLE LOCAL CODES. THIS INCLUDES PROPER GROUNDING AND BONDING OF THE SCOREBOARD.

NOTES

1. MAKE CONNECTION TO EYEBOLT PER OWNER'S SPECIFICATIONS.
2. ANCHORS AT CEILING FURNISHED BY OWNER.
3. WIRE ROPE CABLE EACH CORNER SIZE AS REQUIRED TO SUPPORT SCOREBOARD. CABLE FURNISHED BY OWNER.

TYP. PERMANENT INSTALLATION 4-FACE-2550-D		 NEVCO SCOREBOARD CO. GREENVILLE, ILLINOIS 62246
DRAWN HW	DATE 4/29/98	SHEET 1 OF 1

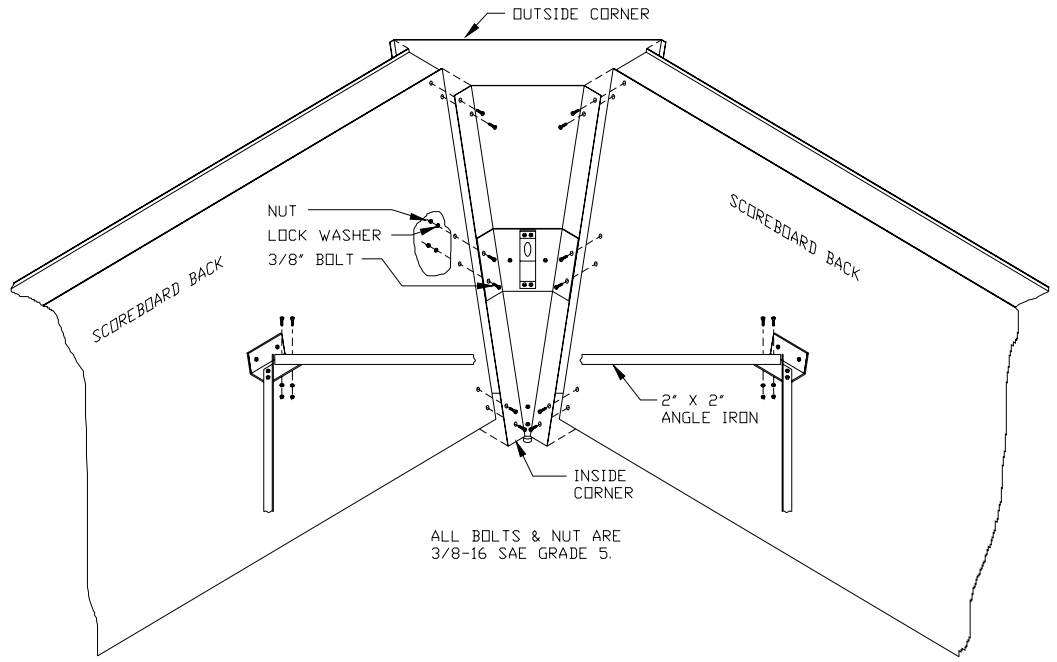

CORNER ASSEMBLY DETAIL

ALL BOLTS & NUT ARE
3/8-16 SAE GRADE 5.

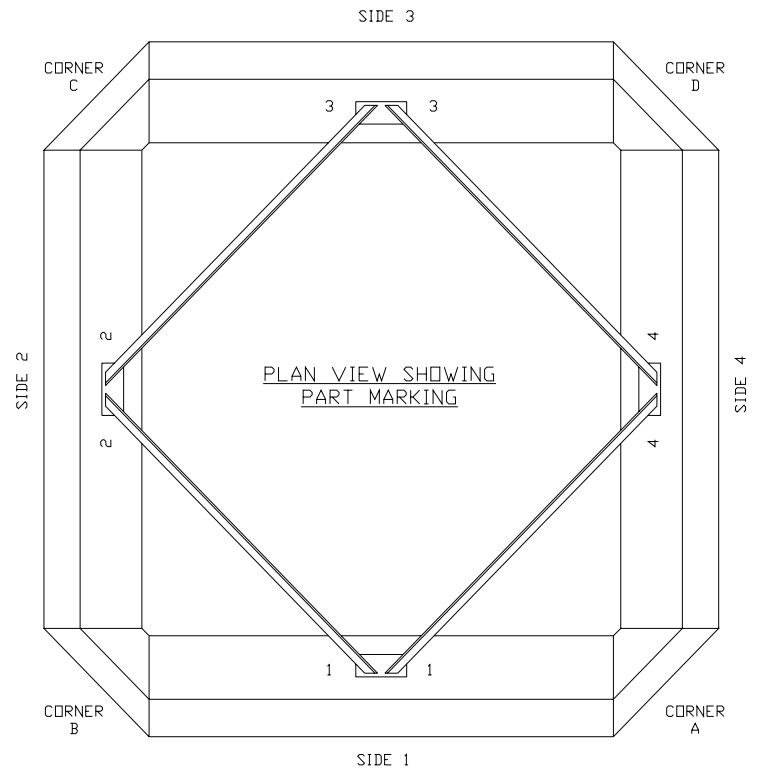

PLAN VIEW SHOWING
PART MARKING

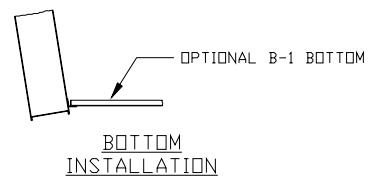

BOTTOM
INSTALLATION

TYP. ASSEMBLY 4-FACE SCOREBOARD		 NEVED SCOREBOARD CO. GREENVILLE, ILLINOIS 62246
DRAWING NO. D1888		
DRAWN HW	DATE 5-6-75	SHEET 1 OF 1

NOTE

REMOVE EACH SIGN FACE FOR ACCESS TO POWER CONNECTIONS. ADD HOLES IN REAR OF SIGNS FOR POWER ENTRANCE.

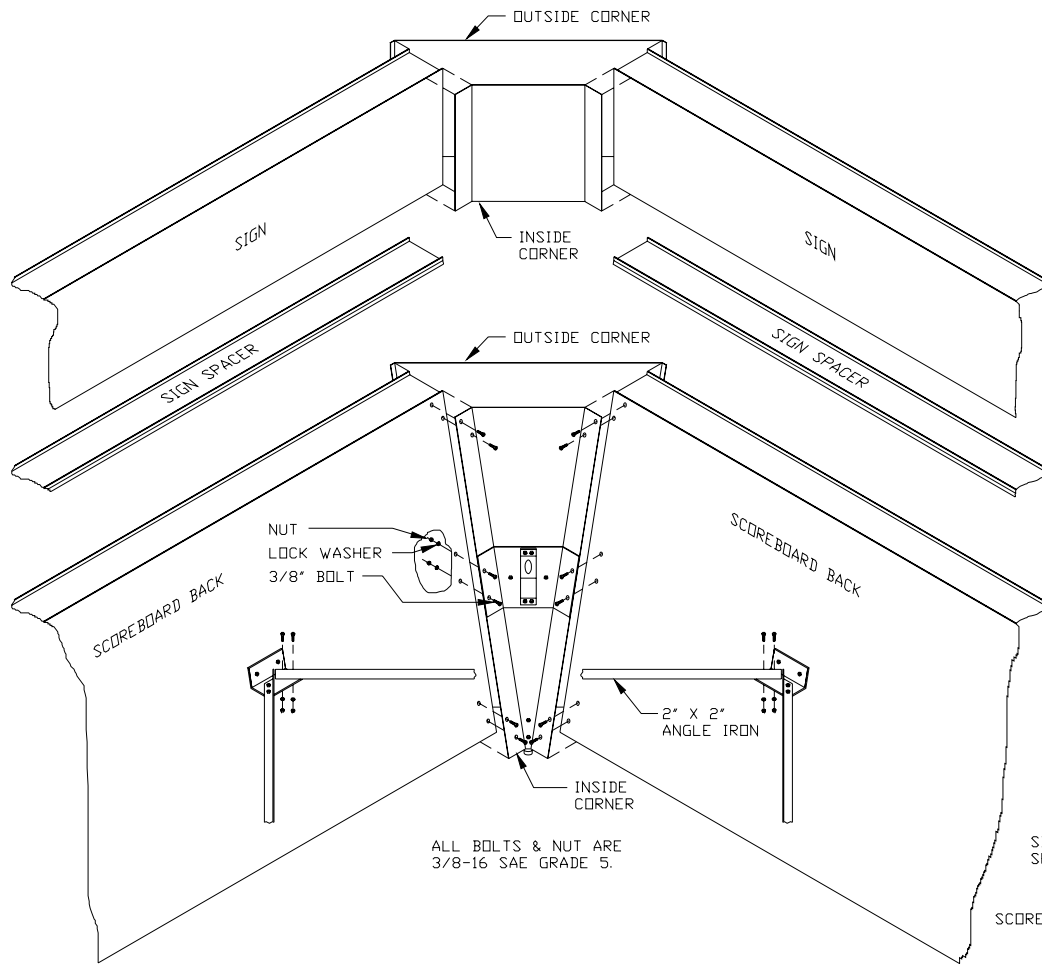

ALL BOLTS & NUT ARE
3/8-16 SAE GRADE 5.

CORNER ASSEMBLY DETAIL

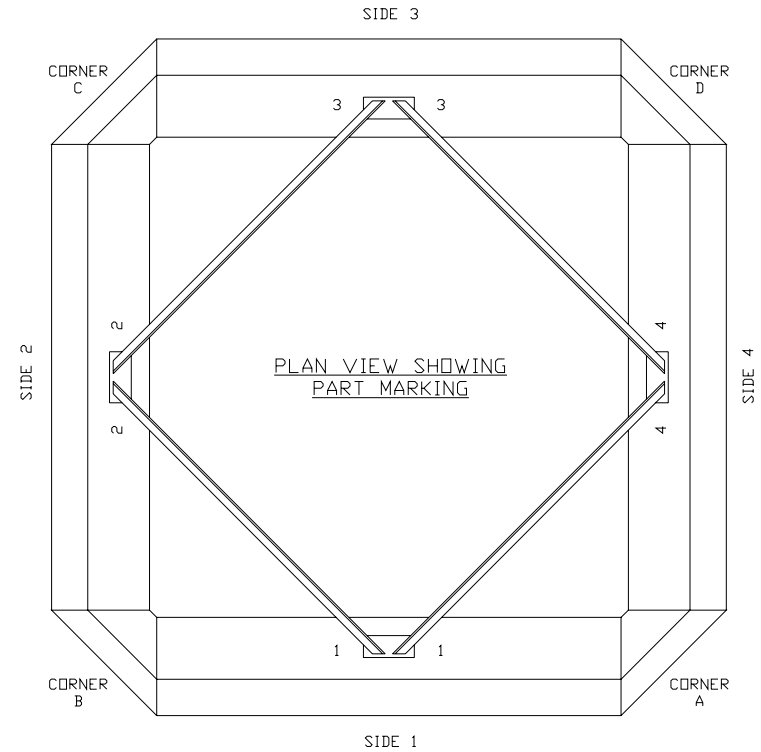

PLAN VIEW SHOWING
PART MARKING

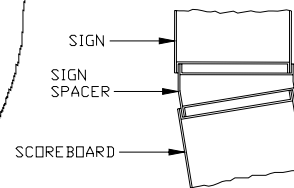

SIGN ATTACHMENT
DETAIL

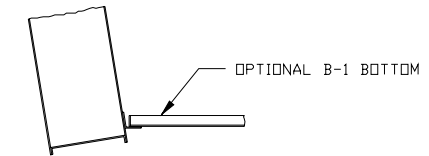

BOTTOM
INSTALLATION

TYP. ASSEMBLY 4-FACE SCOREBOARD WITH AD SIGNS OR ADL SIGNS		 NEVCD SCOREBOARD CO. GREENVILLE, ILLINOIS 62246
DRAWING NO. D3108		
DRAWN HW	DATE 1-30-79	SHEET 1 OF 1

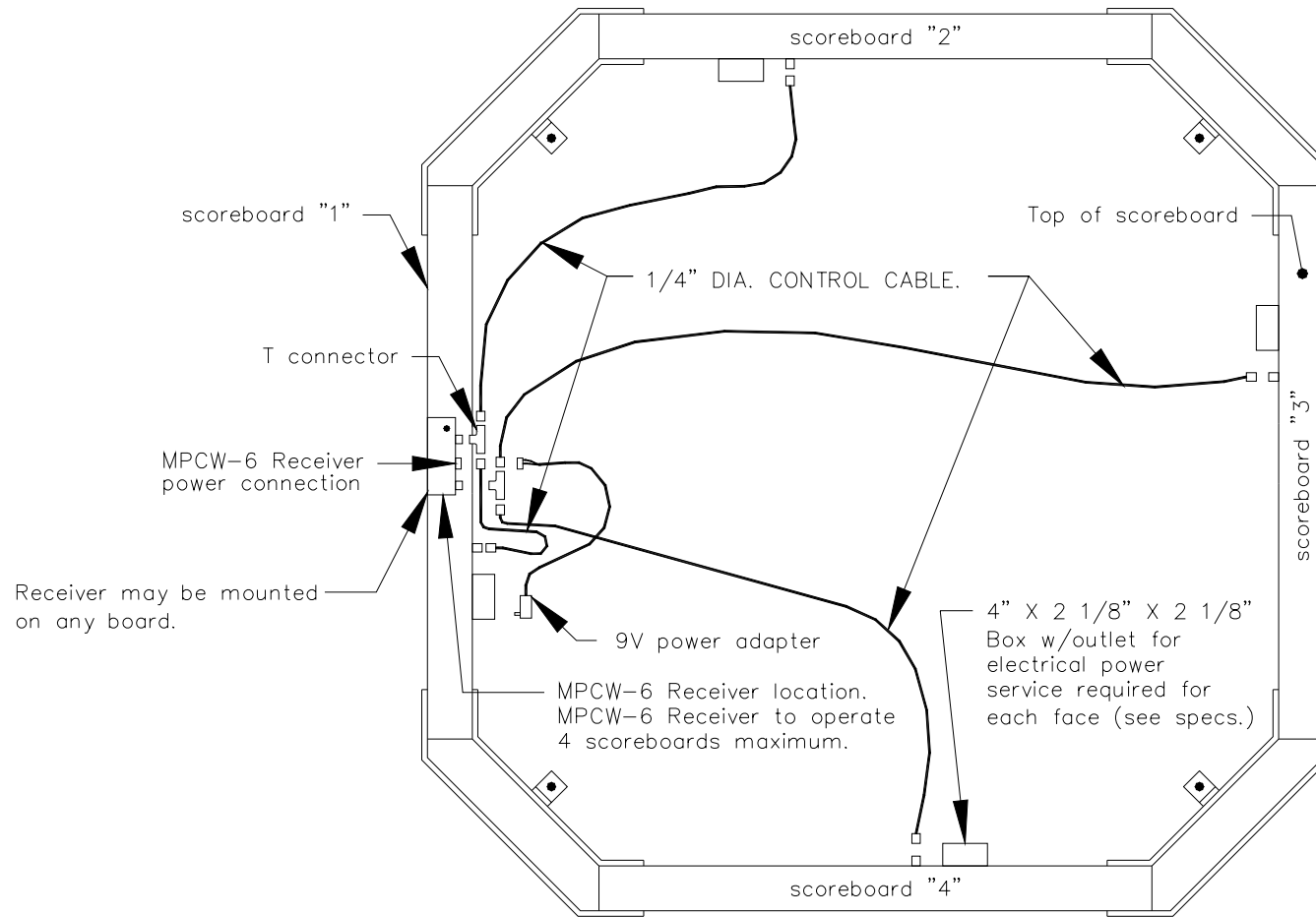

MPCW-6 RECEIVER TOP
VIEW OF 4-FACE SCOREBOARD

NOTES:

1. If a sign is added to the top of the scoreboard the receiver must be placed on top of the sign.
2. Use power adapter extension if signs are mounted to the top of scoreboard.
3. To independently operate each scoreboard face, each face must have its own MPCW receiver.

RECEIVER MOUNTING
DETAIL, 4-FACE
SCOREBOARD W/1
MPCW-6 RECEIVER



NEVCO SCOREBOARD CO.
GREENVILLE, ILLINOIS 62246

DRAWING NO. C10089

DRAWN BMK DATE 11/01/04

SHEET 1 OF 1

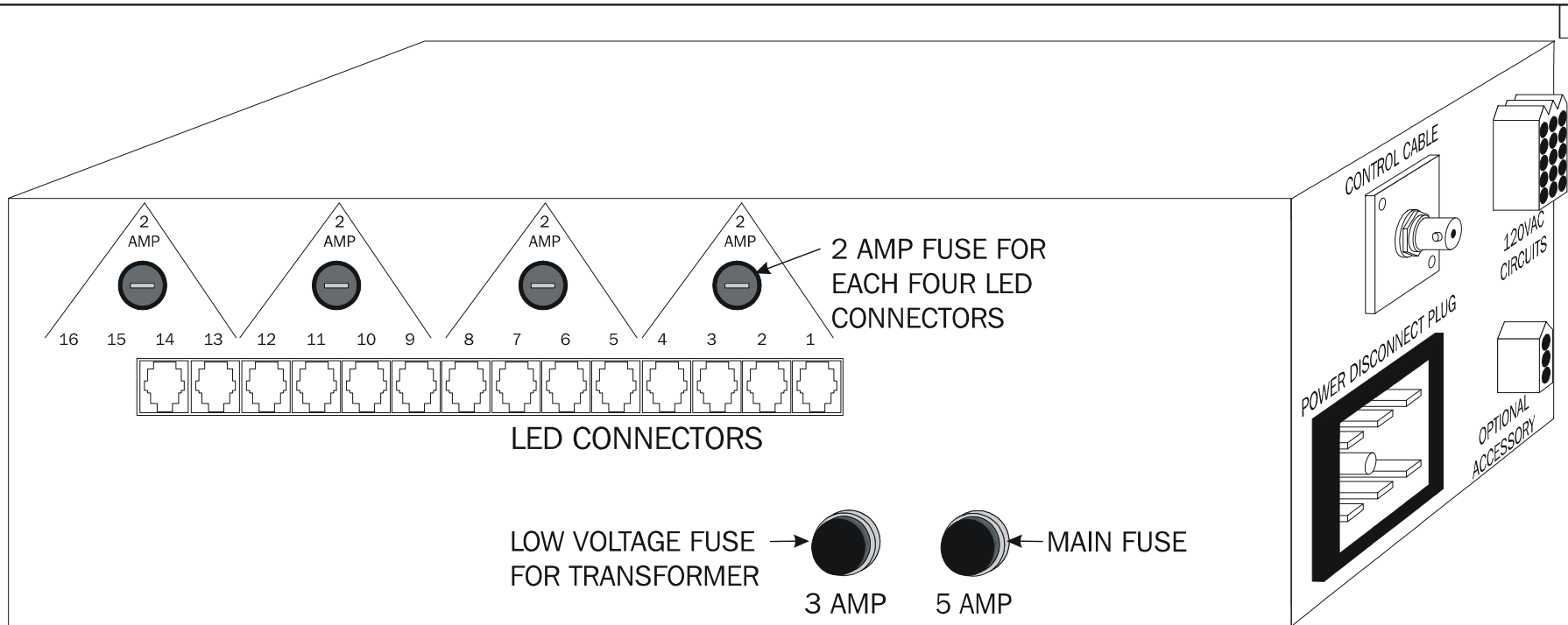

"E" and Error Counter Locations
 Plug 1 = E
 Plug 13 = Counter

LED Connector Functions

120VAC Circuits

- 1 Guest Score Ones
- 2 Guest Score Tens & Hundreds
- 3 Guest Fouls & Tens
- 4 Player Number Ones
- 5 Player Number Tens & dash
- 6 Digital Period
- 7 Time seconds Ones
- 8 Time seconds Tens & Decimal
- 9 Time Minute Ones & Colon
- 10 Time Minute Tens
- 11 Player Fouls & Colon
- 12 Home Score & Tens
- 13 Home Score Ones
- 14 Home Score Tens & Hundreds
- 15 N / A
- 16 N / A

- 1 Home Poss
- 2 Guest Bonus
- 3 G.L. Non switchable
- 4 Guest Poss
- 5 Home Bonus
- 6 Basketball General Lights
- 7 Horn Guest
- 8 Horn Home
- 9 Bout / Match
- 10 N / A
- 11 N / A
- 12 N / A
- 13 N / A
- 14 Ground
- 15 Ground

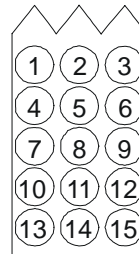

120VAC Circuits

MODULE ILLUSTRATION FOR M14-53		 NEVCO SCOREBOARD CO. GREENVILLE, ILLINOIS 62246
DRAWING NO. C8183		
DRAWN	DATE	SHEET
PEF	06/16/01	1 OF 1

Nevco Scoreboard Company

Scoreboard Testing and Troubleshooting Guide

Indoor LED Models



COUNT ON US

Since 1934

Retain this manual in your permanent file.

Scoreboard Module and Operation Testing

Because the microcomputer is capable of “masking” weaknesses in the scoreboard system, it is important that it reveal problems so corrections can be made before they get worse. A special command can be sent from the control to start the **scoreboard self-test** program. Please consult the **Control Hookup and Troubleshooting Guide** for instructions on initiating and terminating the following tests.

Control Signal Test

Consult the **Control Hookup and Troubleshooting Guide** for availability and instructions.

Scoreboard Self-test

Consult the **Control Hookup and Troubleshooting Guide** for instructions on initiating this test.

Light Circuit Test

When the **Scoreboard Self-test** is started, an “E” will appear in the Guest Score Unit’s section of the scoreboard for about a second before the **Light Circuit Test** starts. One LED segment will illuminate in all digits in succession for two rotations. An eight will then display in one digit at a time, starting with plug one of the module for two rotations. Next the captions will rotate twice, (some models do not have rear lit captions) starting with pin one of the circuit plug. You may check the eight and caption rotation pattern by looking at the module illustration print to ensure the cables are plugged in correctly. This pattern will continue until you either reestablish communications from the control or turn off the power to the scoreboard.

Make careful note of the caption lamps or LED segments that are not illuminating. Turn the power to the scoreboard off by turning the breaker off. Replace all lamps or LED segments that did not light and restore power to the scoreboard. Repeat the procedure above to restart the light circuit test. Contact Nevco Service Department for help.

Troubleshooting Guide

A scoreboard malfunction normally results from a component failure or a bad mechanical connection. This troubleshooting guide helps to locate the failure. This information can then be reported to the Nevco Service Department.

PROBLEM:

The scoreboard does not illuminate even though the control seems to operate correctly.

SOLUTION:

- ❑ Check the circuit breakers associated with the scoreboard.
- ❑ Check all 2-WIRE cables and connections.
- ❑ With the power turned off, check all fuses on the module located inside the scoreboard cabinet. Refer to the installation print for module location.
- ❑ Consult the **Control Hookup and Troubleshooting Guide** for more help.

PROBLEM:

Control does not respond when turned on and the scoreboard does not illuminate.

SOLUTION:

- ❑ See **Control Hookup and Troubleshooting Guide**.

PROBLEM:

A single segment in a particular numeral does not light.

SOLUTION:

- ❑ Turn the power service to the scoreboard off.

NOTE: Power is still applied to the scoreboard module(s) even with the control turned off.

- ❑ Remove the cover from the LED unit and check all wire connections. Turn the power on. If the segment is still unlit, continue with next step.
- ❑ Turn power service to the scoreboard off. Refer to module illustration print, which shows module plug numbers and their use. Locate the plug that is not working properly. Check the plug for firm connection.
- ❑ Interchange the plug in question with a plug that is known to work:

If the LED segment lights after exchanging plugs, a problem exists in the module. Return the module to the Nevco Service Department for repair.

If the segment remains unlit, the problem is in the LED unit or the segment itself. Turn the power service to the scoreboard off and replace the segment. If the problem persists, contact the Nevco Service Department.

PROBLEM:

Two segments in the same numeral do not turn off when the control is turned off.

SOLUTION:

A problem exists in the module. Carefully document the location of the segments and return the defective module to the Nevco Service Department.

If the problem persists please contact the Nevco Service Department.

800-851-4040

Nevco Guarantee

Nevco scoreboards are guaranteed for a period of five (5) years** from the date of invoice against defects in workmanship or material and will be replaced or repaired without cost to the owner provided the equipment or parts (which includes LED segments) are returned postage-paid to the Nevco factory. Shipping back to the owner will be surface postage prepaid except if air or special method of return is specified; then shipping will be freight collect. Lamp bulbs are excluded from this guarantee. Nevco Scoreboard Company will pay no charges for time or material used by others in making repairs or corrections. Guarantee shall be void if: any alteration or service, other than unplugging modules or controls, is performed without Nevco factory authorization; or if the equipment has been connected to incorrect power, or is improperly grounded or improperly installed. Equipment which is subjected to accident, neglect, abuse, misuse or other natural disasters, including but not limited to: fire, wind, lightning, flood, is not covered by this guarantee.

** Nevco wireless equipment is guaranteed for a period of two (2) years from the date of invoice. . All other terms and conditions of this guarantee remain the same.

NEVCO SCOREBOARD COMPANY

**301 East Harris Avenue
Greenville, IL 62246-2151 USA**

Telephone: 618-664-0360

Fax: 618-664-0398

TOLL-FREE 800-851-4040

From all 50 states and Puerto Rico

— **IN CANADA** —

NEVCO SCOREBOARD COMPANY ULC

107 Forestview Rd., P.O. Box 2629

Orillia, ON L3V 7C1 Canada

Toll Free: 800-461-8550

Fax: 705-325-8891

Website: www.nevco.com

Email: info@nevco.com



**Scoreboards · Message Centers
Video Displays**

Since 1934

NOTE: This equipment has been tested and found to comply with the limits for a Class A digital device, pursuant to part 15 of the FCC Rules. These limits are designed to provide reasonable protection against harmful interference when the equipment is operated in a commercial environment. This equipment generates, uses, and can radiate radio frequency energy and, if not installed and used in accordance with the instruction manual, may cause harmful interference to radio communications. Operation of this equipment in a residential area is likely to cause harmful interference in which case the user will be required to correct the interference at his own expense.

This class A digital apparatus meets all requirements of the Canadian Interference- Causing Equipment Regulations.

Cet appareil numerique de la classe A respecte toutes les exigences du Reglement sur le materiel brouiller du Canada.

Service Request

Scoreboard Serial # _____

Service: Module(s) Serial # _____

Service: Control(s) Serial # _____

Comments: _____

Parts Request

	Quantity	Part No.	Description
1.	_____	_____	_____
2.	_____	_____	_____
3.	_____	_____	_____
4.	_____	_____	_____
5.	_____	_____	_____

Contact, Shipping, and Billing Information

Person to Contact: _____ Phone # _____

E-Mail: _____

Ship To: _____

Street _____

City _____ State _____ Zip Code _____

Ship Via _____

Bill To: _____ Purchase Order # _____

P.O. Box # _____

Street _____

City _____ State _____ Zip Code _____

We will contact you with the amount of your purchase before charging your account.

Charge To: _____
Name exactly as it appears on credit card _____ Signature _____

Credit Card: American Express MasterCard VISA

_____ Expiration Date: ____/____
Credit Card Account Number Month Year

Make a copy of this form to order parts needed and/or to return with item to be serviced.

